



# Elvion Natura

MANUAL

elvion



## **ENGLISH**

1.	PARTS	4
2	PRECAUTIONS	5
3	INSTALLATION	6
4	SETTINGS	10
5	START UP	11
6	CLEANING	13
7	REMARKS	15

# 1. PARTS

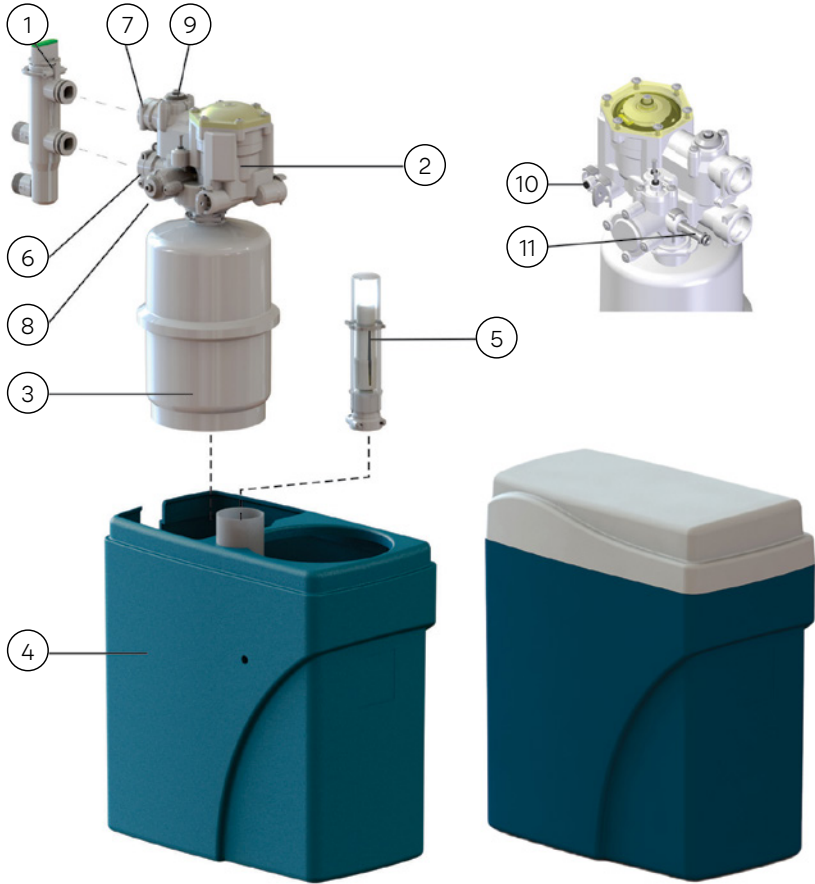

1	BYPASS	7	WATER OUTLET
2	VALVE HOUSING	8	BLENDING REGULATOR
3	RESIN TANK	9	HARDNESS REGULATOR
4	CONTAINER FOR DEVICE AND SALT	10	TO BRINE VALVE
5	BRINE VALVE	11	TO DRAIN
6	WATER INLET		

## 2 PRECAUTIONS

### 2.1 General

- Make sure you have the latest installation manual at hand.
- Read this manual carefully. If you have any questions or remarks, please contact your supplier.
- Make sure you have all necessary tools on hand before you begin with the installation.
- Follow all local legal regulations.

### 2.2 Water to be treated

Check incoming pressure: minimum 1 bar (dynamic), maximum 8 bar (static) (15 PSI- 116 PSI). If necessary reduce incoming pressure.

The pressure behind the softener must be at least 1bar to ensure a good functioning of the softener. If this pressure of at least 1bar can't be guaranteed, a "Pressure Guard" is available at your supplier.

The water should be free of sediment, chlorine, iron and manganese.

### 2.3 Softener

- The softener has to be installed on a flat, stable base.
- The softener must be installed indoors, protected from direct sunlight.
- The softener must be installed on a dry location and certainly not in an acidic environment.
- Do not install the softener close to a heating source (environment temperature must be below 40°C).
- Protect softener and drain (#11) against frost.
- The Bypass is not designed to be left behind without the softener. It is not a shutoff valve.
- The provided overflow has to be installed and connected at all times.

# 3 INSTALLATION

## 3.1 Connect Bypass

Close main valve and make sure pressure is released from piping. This can be done by opening at least one tap.

Cut open main water supply in order to install the bypass to the Softener. Follow the arrows on both Bypass and Softener for water inlet and outlet.

Pay attention that the inlet filter doesn't fall out.

Caution: before installing the Softener, set the Bypass in "bypass" mode, not in "service".

## 3.2 Connect drain

Connect the straight outlet (#11) to a local drain (with an air gap, using the provided Open Drain Connector, see par. 3.4) by means of the provided 13mm flexible drain pipe. In order to guarantee that the device will keep on functioning perfectly in the future, this drain pipe is spirally reinforced to avoid later blocking and/or kinks. Please protect the drain against frost and heat (min. temp. 5°C, max. temp. 40°C).

When another drain pipe is used, the guarantee on the unit is expired.

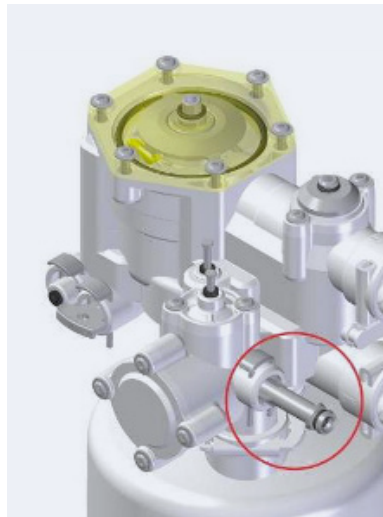
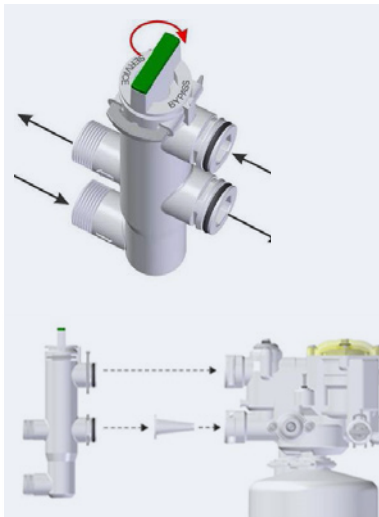

### 3.3 Install overflow elbow

Make sure to install the supplied overflow tap. You can find the overflow in the salt container. The overflow needs also to be connected with the Open Drain Connector (see par. 3.5).

First, pierce a hole ( $\varnothing 21\text{mm}$ ) in the side wall of the salt container. The location of the hole is not important, make sure however that it is approx. 10cm down from the top edge of the salt container.

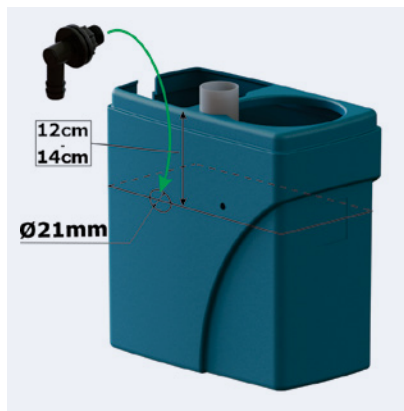

Once the hole has been drilled, mount the overflow tap and secure it with the supplied nut.

After drilling, remove all bits of plastic that have fallen into the salt container.



### 3.4 Connect drain pipes to Open Drain Connector (ODC)

To connect the flexible drain pipe from the softener (par 3.2) and from the overflow (par 3.3) with a fixed drain pipe, you should use the provided Open Drain Connector (ODC).

This part provides the obligatory interruption according to the European standard EN1717. If the softener is connected to a fixed drain pipe without this ODC, the guarantee on the unit is expired.

The part with the two connections and the transparent part are snapped into one another. If they come apart, they can easily be snapped back together.

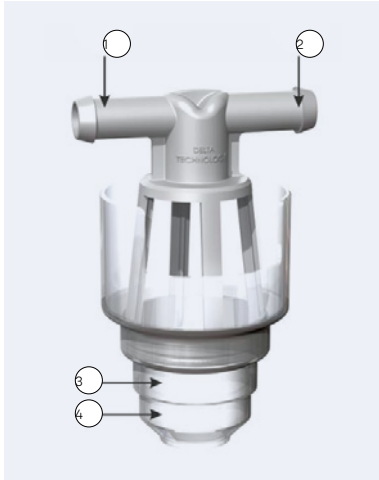

1. Connection 1 for spirally reinforced drain tube Ø13mm.
2. Connection 2 for spirally reinforced drain tube Ø13mm.
3. Connection 3 for socket. (drain pipe Ø40mm)
4. Connection 4 for drain pipe Ø40mm.

1. Connect the spirally reinforced drain tube Ø13mm, that comes from the unit, with one of the two connections on the ODC. Push it on as far as possible.



2. Connect the spirally reinforced drain tube Ø13mm, coming from the overflow, with the other connection. Push it on as far as possible. This is only possible if the overflow of the salt container is higher than the connection on the ODC.

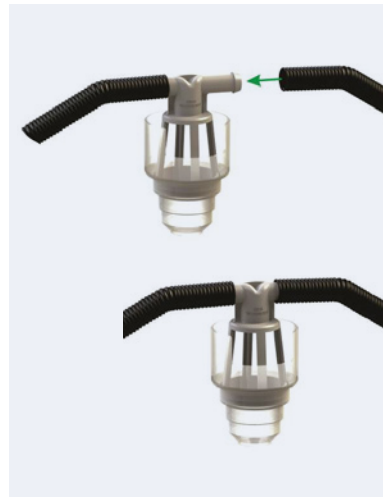

3. If the part with the connections for the tubes is disconnected from the transparent part, snap them back together. Even if the two parts are snapped together, they still can rotate. This means that the orientation of the connections can be adapted. In case the two parts keep disconnecting, you can glue them together.

4. Now glue the complete ODC in a fixed drain pipe  $\text{\O}40\text{mm}$  or a socket  $\text{\O}40\text{mm}$ . Make sure that the ODC is mounted horizontally and that the part with the connections is still snapped in the transparent part.

Respect a minimum distance of 100mm between the bottom of the ODC and the drain pipe. (see picture)

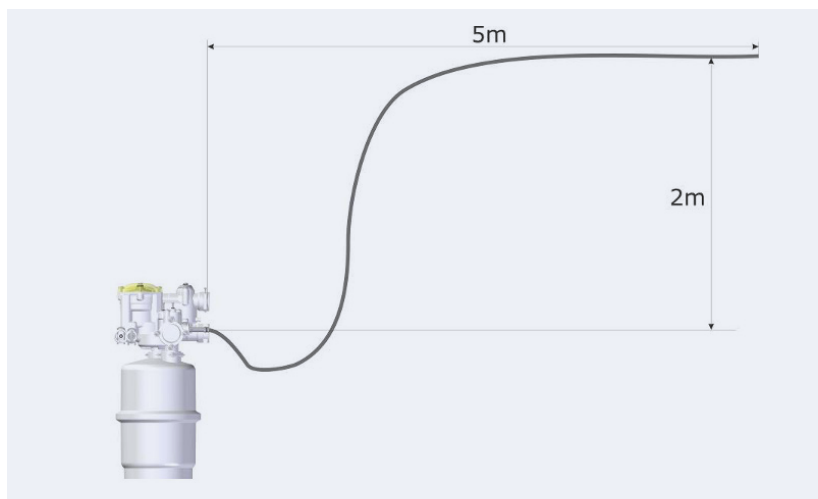
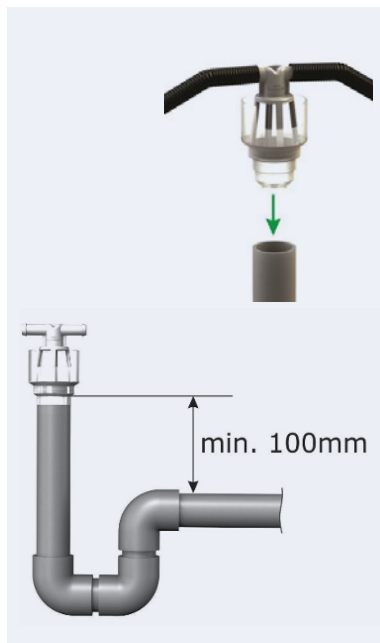

maximum height and distance of flexible drain hose.

## 4 SETTINGS

### 4.1 Hardness regulator

= part number 9 on the illustration on page 4.

Measure the hardness of incoming water by means of a hardness test kit (not supplied with the unit).

The setting of this unit is in CaCO<sub>3</sub>. (10 ppm CaCO<sub>3</sub> = 1°fh) (1°dh = 1,78°fh)

Adjust the hardness regulator to the measured value. This requires a hex key number 5.

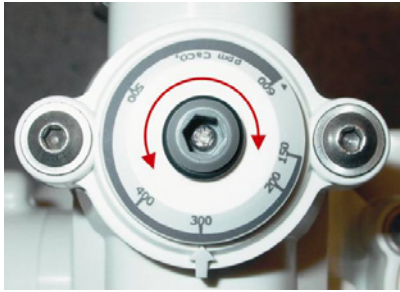

### 4.2 blending regulator

= part number 8 on the illustration on page 4.

With the blending regulator, you can determine the outgoing hardness.

Depending on the desired residual hardness, set outgoing hardness with a hex key number 5. The setting is proportional, i.e. 1/10 – 1/5 – 1/... of total incoming hardness.



## 5 START UP

1. Leave Bypass in “bypass” mode, open main valve and flush for several minutes in order to avoid impurities from entering the softener.
2. Fill salt bin with salt in the provided space. Use only specific salt tablets that are suitable for water softeners.



3. Add water in the salt bin until the water level is approx. 10cm (4”) high. (the floater on the brine valve must be afloat).

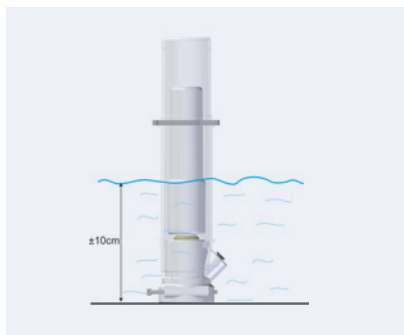

4. Turn the bypass slowly to “service” mode.

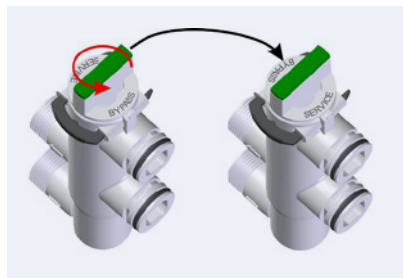

5. Open a tap behind the Softener so a flow runs through it. Some air may flow from the tap; this comes from the Softener. This will happen only once; at start-up. Once only water flows from the tap, and no more air, close the tap.

6. Perform a manual regeneration.

- Use a hex key number 5 to turn the program disk (PRG) manually. Turn PRG counter clockwise until it is in above position. When the arrow and the small line on the transparent cover reach the area marked by “B” (brining), the regeneration will start. Immediately, the PRG will drop down a little (you will be able to see and hear this). “R” stands for refill (refilling the container with water at the end of the regeneration stage).

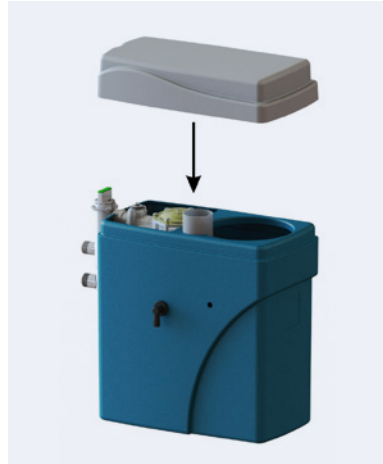
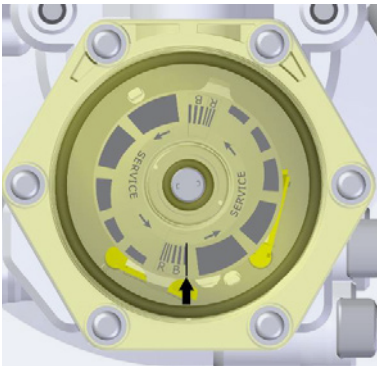
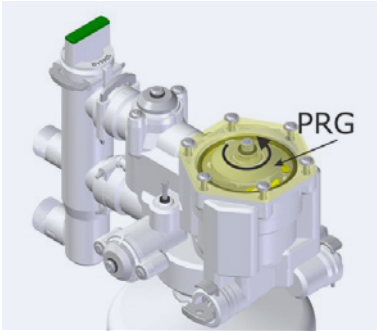

- Open a tap behind the Softener for several minutes to allow residual water to be flushed from the tubing.
- Check outgoing hardness with a “hardness test kit”. Adjust blending if necessary.
- Place the lids on the container.

- To make sure the Softener is in regeneration, there should be a small water flow to the drain, and the water level in the container should drop.
- Let the regeneration perform until it stops automatically. The estimated time is approx. 15 minutes. When regeneration has stopped, no more water flows to the drain. This is a clear indication that the regeneration stage is over.

## 6 CLEANING

### 6.1 Unit

It is only allowed to clean the outside of the unit with a damp cloth. The use of abrasives, detergents, soaps and / or detergents is never permitted.

### 6.2 Resin

The only cleaning agent that is allowed for the resin is Resin Clean. The use of liquid acids or bases will affect the working of the resin and damage the synthetic material.

Failure to comply with these regulations, a failure of the device or accident claim will not be eligible for warranty and stops the product responsibility of the manufacturer.

1. Disconnect the black tubing Ø4mm from the valve. Push the black ring on the coupling and pull out the black tube. (see picture)
2. Connect the end of a 50cm part black tubing Ø4mm with the valve. Push it in the press fitting as far as possible. The other end of the tubing Ø4mm goes into the bottle Resin Clean.

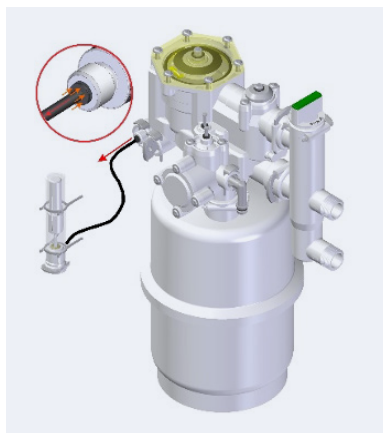

3. Use a hex key number 5 to turn the program disk (PRG) manually.

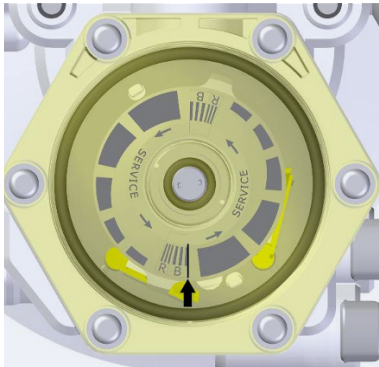
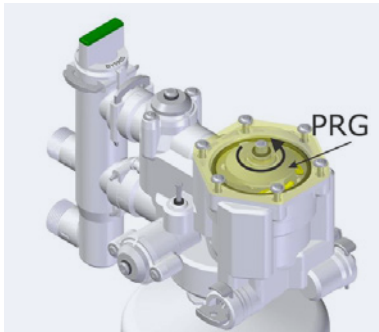

Turn PRG counter clockwise until it is in above position. When the arrow and the small line on the transparent cover reach the area marked by "B" (brining), a regeneration will start. Immediately, the PRG will drop down a little (you will be able to

see and hear this). Now the unit will start sucking up some Resin Clean.

4. Let the unit suck up 125ml Resin Clean. After sucking up the Clean, disconnect the Ø4mm tubing from the valve and push the black Ø4mm tubing, coming from the brine valve, back in the press fitting on the valve.

The unit will now complete its regeneration. After the suction, zone marked with the letter 'B' (=Brining), the program disk rotates until the arrow comes into the zone marked with the letter 'R'. The letter 'R' stands for refill. (the refilling of the containers with water at the end of the regeneration).

5. Let regeneration perform until it stops automatically. The estimated time is approx. 15 minutes. When regeneration has stopped, no more water flows to the drain. This is a clear indication that the regeneration stage is over.
6. Open a tap behind the softener for several minutes to allow residual water to be flushed from the tubing.

## **7 REMARKS**

- It is recommended that a water Softener is installed by a professional. Although this softener is probably the easiest and safest softener on the market, it is imperative that all necessary precautions are taken and local legislation is followed.
- This installation guide is written to help the professional installer keeping in mind that this person has essential knowledge about hydraulic softeners and domestic plumbing.
- Proper working of the softener will be determined by proper installation.
- An annual control of your softener will guarantee optimal functioning and a long operating life.

**elvion**

**elevate**  
*your*  
**water**

Elvion is available at top  
Builders Merchants nationwide.

[www.elvionwater.co.uk](http://www.elvionwater.co.uk)  
[www.elvionwater.ie](http://www.elvionwater.ie)